

⑪ ① No. 991373

④⑤ ISSUED 760622

⑤② CLASS 20-33.4
C.R. CL. 20-119

①⑨ ①⑩

CANADIAN PATENT

⑤④

SHAPE-LOCKING JOINT CONNECTOR FOR PANEL-SHAPED
CONSTRUCTION ELEMENTS WITHOUT ANY SEPARATE
CONNECTING PARTS

⑦⑩

Hebgen, Heinrich, Germany (Federal Republic of)

②①

APPLICATION No. 177,870

②②

FILED 730801

③⑩

PRIORITY DATE Germany (Federal Republic of) (P 22 38 660.3) 720805

No. OF CLAIMS 11

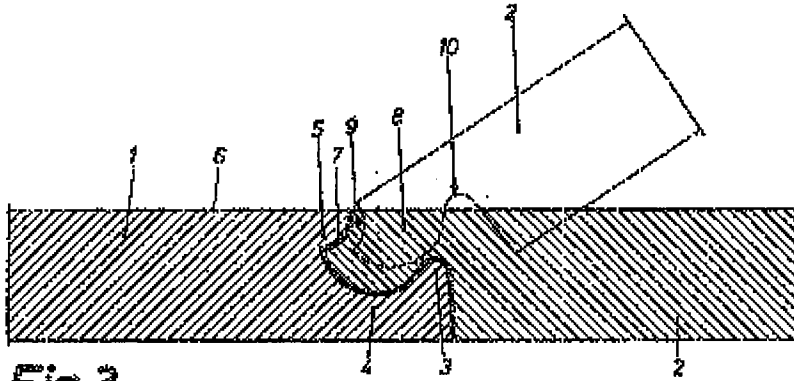

Fig. 3

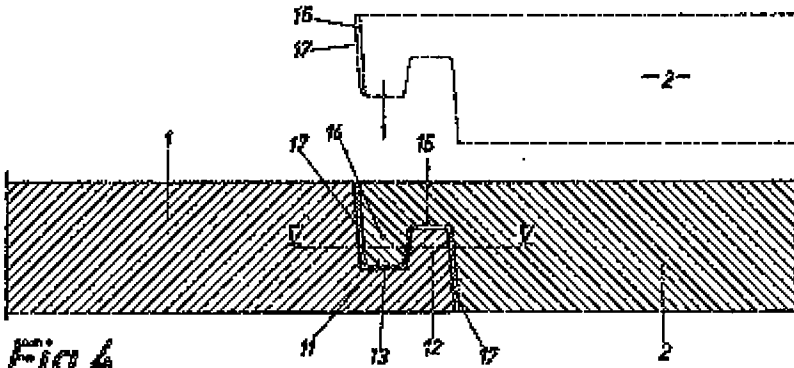

Fig. 4

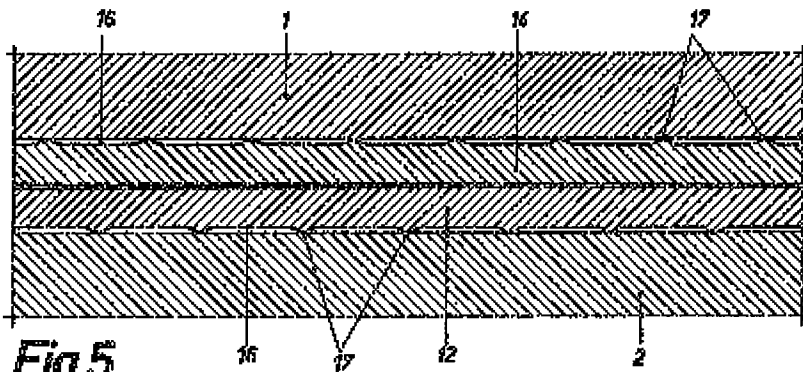

Fig. 5

*Patent Agents
Larsson & Larsson + Co*

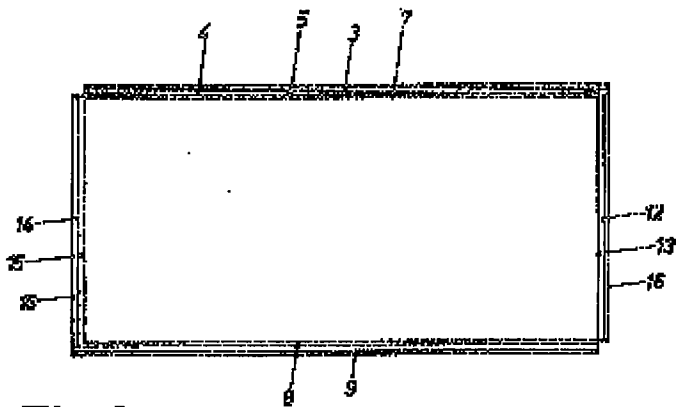

Fig.6

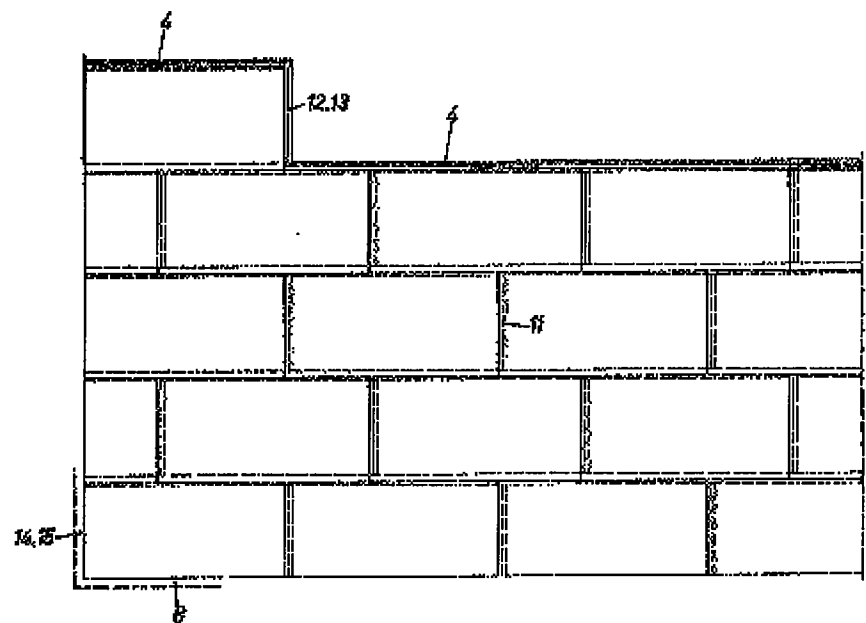

Fig.7

*Patent Agents
Kendall & Knapik & Co.*

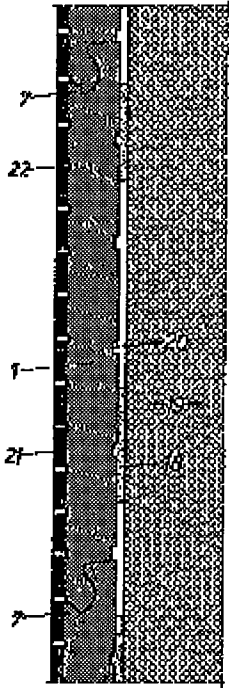

Fig.8

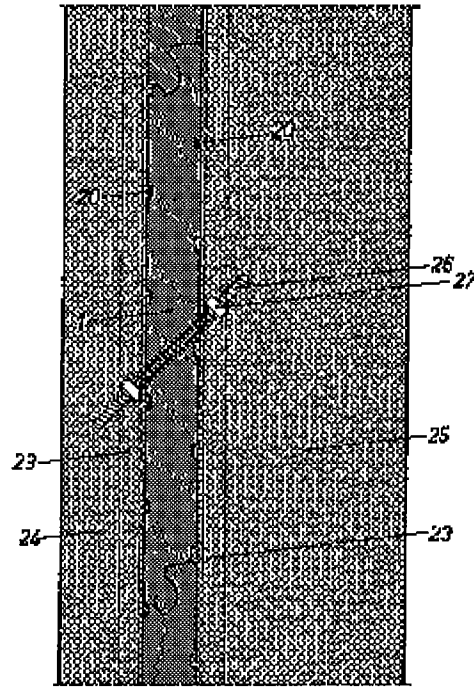

Fig.9

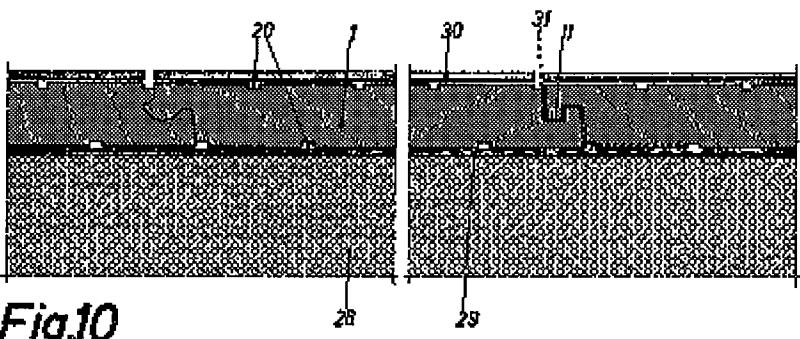

Fig.10

Patent Agents



991373

THE EMBODIMENTS OF THE INVENTION IN WHICH AN EXCLUSIVE PROPERTY OR PRIVILEGE IS CLAIMED ARE DEFINED AS FOLLOWS:

1. A form-locking connection for panel-shaped construction elements without separate connectors, characterized in that on one edge of the construction element there is a rounded channel that is open to the outer surface of said construction element, said channel being followed by an edge strip, said channel having a stop strip on the side opposite the edge strip, said stop strip being flush with the outer surface and protruding into the space formed by said channel, while the corresponding edge of the adjacent construction element is of a shape that corresponds to this configuration to ensure form-locking engagement with the edge.
2. A form-locking connection according to Claim 1, characterized in that the radius of the channel is arc-shaped in cross-section.
3. A joint according to Claim 2, characterized in that the radius of the channel is approximately one-half the thickness of the construction element.
4. A joint according to Claim 1, characterized in that the stop strip is arc-shaped on its circumference in cross-section.
5. A joint according to Claim 4, characterized in that the stop strip is formed in cross-section as a quadrant, the radius of said quadrant being approximately one-quarter the thickness of the construction element.
6. A joint according to Claim 1, characterized in that the centre point of the channel and the point of intersection of the channel and the stop strip lie in a plane that is parallel to the plane of the construction element.
7. A joint according to Claim 1, characterized in that the centre point of the stop strip lies at the point of intersection of the tangent to the channel that is perpendicular to the plane of the construction element and the outer surface of the construction element.



991373

8. A joint according to Claim 1, characterized in that the height of the edge strip is approximately one-half to three-quarters the thickness of the construction element.

9. A joint according to Claim 1, characterized in that it is arranged on two opposite edges of a rectangular insulating panel of foamed synthetic resin.

10. An insulating panel according to Claim 9, characterized in that the remaining edges of the panel are provided with known joints, oriented towards opposite sides of the panel, said joints consisting of interlocking grooves that are continuous along the whole of the side of the panel.

11. An insulating panel according to Claim 10, characterized in that the edges of the panel are provided on the front faces with bead-like thickened portions, arranged at intervals and running perpendicular to the plane of the panel.





001373

The invention relates to a shape-locking joint connector for panel-formed construction elements, without any separate connecting parts.

The simplest manner of joining construction elements together is by a butt joint. However, a butt joint can only withstand compression forces; it cannot withstand tensile forces nor lateral forces.

A simple or compound step joint can transmit compressive forces that act in a specific direction, but it cannot transmit tensile forces. Compressive and lateral forces can be absorbed, for example, by means of a tongue-and-groove joint, but this joint cannot transmit tensile forces.

10 The so-called hooked step joint is also familiar in connection with insulating panels made of foamed synthetic-resin plastic; in these joints there are grooves accompanied by strips arranged along the edges of the panel that are to be joined. Since they open on different sides of the panel and interlock with each other, they thereby create a joint that can withstand both compressive and tensile forces. However, lateral forces can be transmitted only to a limited extent in such a joint, and then only in one direction.

20 It is the object of the invention to create an effective shape-locking connection for construction elements of all kinds that are, by preference, panel formed, without the use of additional fastenings, such a connection being capable of withstanding compressive, tensile and lateral forces in any direction.

30 According to the invention, there is provided a form-locking connection for panel-shaped construction elements without separate connectors, characterized in that on one edge of the construction element there is a rounded channel that is open to the outer surface of said construction element, said channel being followed by an edge strip, said channel having a stop strip on the side opposite the edge strip, said stop strip being flush with the outer surface and protruding into the space formed by said channel, while the corresponding edge of the adjacent construction element is of a shape that corresponds to this configuration to ensure form-locking engagement with the edge.

In cross-section, the channel is appropriately arc-shaped, its

- 1 -





991373

radius being approximately equal to half the thickness of the construction element. In cross-section, the stop strip is also appropriately arc-shaped. In cross-section, it can be formed as a quadrant of a radius approximately equal to one quarter the thickness of the construction element.

The centre point of the channel and the point of intersection of the channel with the stop strip are best located in a plane that is parallel to the plane of the construction element.

It is expedient that the centre point of the stop strip be located at the point of intersection of the tangent to the channel that is perpendicular to the plane of the construction element, with the top surface of the construction element.

The height of the edge rail is best selected so as to be approximately one-half to three-quarters the thickness of the construction element.

The problem posed is completely solved by the configuration of the edges of the construction element proposed by the invention. The channel that is arranged on one edge of the construction element, and the edge strip, in conjunction with the appropriately-formed edge of the adjacent construction element, provide for a connection that can withstand tensile and compressive forces, while the stop rail, in conjunction with an appropriately-matching recess in the edge of the adjacent construction element, locks the joint against movement in a direction that was not possible using the familiar hooked step joint. The arc-shaped rounding of the channel satisfies the basic requirement that the second construction element, that is to be joined to the first construction element, can be fitted by its edge into the channel of the first construction element, obliquely from above, and when being aligned with the construction element that has already been installed, it locks practically automatically.

Continuous surfaces of any size can be produced using the shape-locking joint according to the invention, without the use of any additional fastenings, such as nails, screws, clamps, adhesives, etc., to connect the individual construction elements. The joint according to the invention also ensures that the construction elements that have been installed all lie in the



991373

some plane and no subsequent levelling operations are required.

The use of the step joint according to the invention is not confined to one specific material. Neither does the fabrication of the undercut portions of the connection present any difficulties. In the case of wood or wood products, the portions of the groove can be milled. In the case of foamed synthetic resin plastics, from which the majority of insulating panels are made, it is possible to provide the production machinery, e.g., the foam machines, with swing-away tool elements which are first of all swung back before the two-part mould opens and releases the foamed panel. Accordingly, the main area of application of the joint according to the invention is in foamed-plastic insulating panels in which it is used on two opposite edges of the panel, while the remaining edges are preferably provided with familiar interlocking grooves that are oriented towards opposite sides of the panel and consist of edge strips that are followed by channels that are continuous over the whole length of the side.

Besides this, the front surfaces of the edge strip can also be provided with protruding areas located at intervals along the said front surfaces, that extend perpendicular to the plane of the panel.

Preferred areas of application for construction elements, especially panels or panel-like forms, that are provided with the joint according to the invention, are ceiling coverings, floor coverings, wall coverings, insulating layers in walls and roofs, etc., thus, in all areas where it is a matter of having continuous, level coverings or overlays.

The invention will now be described in greater detail, by way of example only, with reference to the accompanying drawings, in which:

Figure 1 is a cross-section through the joint according to the invention that illustrates details of the design.

Figure 2 is a cross-section through the two portions of the joint during assembly.

Figure 3 is a cross-section through the joint according to the invention in two insulating panels.

Figure 4 is a cross-section through the hooked step joint on the

Wood

Floors



991373

edges that are perpendicular to those according to Figure 3.

Figure 5 is a longitudinal section on the line V - V in Figure 4.

Figure 6 is a plan view of an insulating panel with the joint according to the invention.

Figure 7 is a part of a wall covered by such insulating panels.

Figure 8 is a cross-section through insulating panels applied to a vertical wall.

Figure 9 is a cross-section through a concrete wall having an insulated core consisting of such panels.

10 Figure 10 is a cross-section and a longitudinal section through a flat roof having external insulation in the form of panels with edges formed according to the invention.

In the cross-section through a joint according to the invention, Figure 2 shows two adjacent construction elements 1 and 2 that have appropriately-configured edges. The edge configuration of the panel 1, on the left of the illustration, has an edge strip 3 that includes a arc shaped channel 4 to one side. On the side of the channel 4 opposite the edge strip 3, a stop strip 5 protrudes into the space formed by the channel, and this stop strip is flush with the top surface 6 of the panel 1, reaching with an arc-shaped curved portion 7 from the top surface 6 of the panel to the channel 4.

20

The right-hand panel 2 has an edge configuration that corresponds to the edge configuration of the panel 1 like a counter die matches a die. This edge configuration consists of a thickened portion 8 that fits in the channel 4 and has at its outer edge a recess 9 that corresponds to the stop strip 5. This edge configuration fits and locks, by virtue of its shape, into the edge configuration of panel 1, the outer surface of the thickened portion 8 sliding along the arc-shaped curved portion 7 that corresponds to it, until the recess 9, which is also arc-shaped, rests against the correspondingly-curved stop strip 5 and the edge channel 10 covers the edge strip 3. Thus the

30 joint is automatically locked.

Certain specific dimensional relationships have shown themselves to be particularly expedient for the configuration of the joint according to



991373

the invention. These relationships are shown in Figure 1.

If D represents the thickness of the panel, then the centre point B_1 for the arc-shaped channel is located at a distance of $D/4$ below the top edge of the channel. The radius of the arc that contains the channel is $D/2$. The centre point B_2 for the arc that is contained by the stop strip lies on the tangent to the circle forming the channel, which tangent originates at point A , and is perpendicular to the plane of the panel, where the tangent intersects with the surface of the panel. The radius of the arc is $D/4$.

The first coordinate for the outer point H of the edge strip that forms the boundary of the channel is found by producing the side $B - C$ of the triangle A, B, C that is drawn on the diameter $A - C$ of the channel-forming circle with radius $D/2$. The second coordinate for the point H is found by producing a line from the centre B_1 of the circle through point G to the extended line $B - C$. The point G is located at the point of intersection of a line, drawn parallel to $A - C$, at a distance of $D/8$ below $A - C$, and the circumference of the circle drawn with centre B_1 . According to the area of application and the loading that is to be applied to panels that are provided with joints according to the invention, the thickness D of the panel can be increased in either direction. This increase in thickness is represented by the dotted lines in Figure 1. In the case of materials, such as foamed synthetic resin plastics, that are less capable of bearing loads, the panel should be thickened by extending it upwards, whereas panels that are subjected primarily to tension are best thickened by a downwards increase.

Several sections through insulating panels of foamed synthetic resin plastic are shown in Figures 4 - 5. These panels are provided with joints according to the invention. Figure 5 corresponds approximately to Figure 1; in this case the joint is arranged on both long sides of insulating panels that measure 100×50 cms in most cases.

During laying, the lower portion 4 of the joint always faces in the direction of application. The upper portion 8 of the next panel can then be easily inserted when slanted slightly, since displacement is possible on the curved surfaces. As soon as each newly-laid panel is flush, it is automatical-



991373

ly locked in position, whereupon the adjacent panel is stopped in the prescribed position both in the plane of the panel and perpendicular to this.

There is a hooked step joint 11 on both narrow sides. This joint consists of a lower rail 12, the lower channel 13, the upper rail 14 and the upper channel 15. It is expedient that there be small bulges 17 on the outer edges 16. This will ensure that the parts of the joint are not in continuous contact; this can be advantageous, for example, for allowing water to escape from the inverted flat roof shown in Figure 40. The bulges 17 also ensure that the parts of the joint that have been interlocked stick somewhat, and the panel 1 that has been laid is held in position until such time as the next row of panels 2 with its joint that stabilises the perpendicular thrust, has been installed.

The lower rail 12 and the upper rail 14 only touch the edges of the adjacent joint at the bulges 17 formed on the edges 16. Thus the joint can be fitted together without any special effort; neither is there any longer the danger that underlying insulating panels that have been laid in a bed of fresh concrete will be disturbed when the rail 14 of the new panel is inserted.

The insulating panels of foamed synthetic resin, for example, polystyrol, are produced in a standard shape, and have the joint and the configuration of the panel surfaces formed at this time. Insulating panels made in this way are of a precise size and perfectly square, by which characteristic they differ fundamentally from so-called cut panels. On the upper edge of the drawing at Figure 6 there is the lower portion 4 of the joint, and on the lower edge there is the matching upper portion 8. Parts 4 and 8 are open along their whole lengths in order that they can be positioned at any position over previously laid panels. Both sides of the panel 1 show, on the right, the lower rail 12 with the lower channel 13 and, on the left, the upper rail 14 with the upper channel 15. The edges 16 of the panel are provided with the bulges 17.

Figure 7 is a partial view of a wall covered with panels according to the invention. The upper portions 8 of the lowest row of panels that rests, for example, on a base, are to be removed, as are the upper portions





991373

14 and 15 of the hooked joint 13 of all the panels on the surface of the wall. As soon as the first row has been installed, a start can be made in installing the second and subsequent rows. The vertical joints 11 are to be staggered. The lower portions 4 always face in the direction of application. The upper portion 8 that is inserted therein stabilises the transverse joints. In addition to this, the panels that are located below are automatically pressed into alignment.

Figures 8, 9 and 10 show practical applications of the new panels.

10 The new panels 1 can be used to advantage for covering walls, for example, for single-layer external insulation. For this purpose, they are applied to the masonry 19 with adhesive plaster 18. In order to improve adhesion, there are grooves 20 for the adhesive on the backs of the panels, these grooves running in all directions. During manufacture, these panels 1 are covered with small panels 21. It is expedient that the joints between these panels 21 extend somewhat into the upper surface of the insulating panel. As soon as the insulating panel that is covered in this way has been installed, the whole of the wall that has been covered in this way is pointed so that none of the individual panel joints can be seen. Because of the formation of the joints according to the invention, and especially because of the arrangement of the stop strip 5, it is guaranteed that all the insulating panels 1
20 that have been applied will be flush and form a continuous insulating layer.

The example shown in Figure 9 is a poured concrete wall, that is sheathed and poured during construction, with an insulating core. After the wall sheathing, not shown in the drawing, has been erected, the insulating panels, previously joined together to form an insulating mat, are installed at the prescribed position in the sheathing. They can be additionally stabilized by suitably-shaped metal strips 23. Further, it is expedient to produce the supporting connection between the 6 - 8 cm thick outer layer to the interior supporting wall 25 through the metal strips 23. Anchor bolts 26 can be used
30 for this purpose, these bolts passing through the insulating core 1 and pressing the metal strips 23 to the insulating core 1 by means of nuts 27. When it is poured in, the concrete for the outer layer 24 of the supporting wall 25



991373

surrounds the metal strips 23, thereby providing a permanent connection for the layers of concrete that are separated by the insulating core. For this purpose, the insulating panels 1 are again provided with grooves 20 on both sides. Using the new panels, made-to-measure insulating mats can be prefabricated without the use of special adhesives or the like. Indeed, it is sufficient to have a dry joint between the panels.

Inverted flats roofs are single-layer flat roofs to which are applied a roof sealer, and then a moisture-proof and age-resistant insulating layer, which in turn has to be provided with a coating to protect it against ultra-violet radiation. This protective layer, usually a layer of gravel or concrete slabs, holds the light insulating panels securely in position.

According to Figure 10, the sealing layer, for example, tar paper, plastic sheets or sealant, is applied to the supporting roof, for example, a reinforced concrete roof. The edges of this sealing layer are arranged at the edge of the roof in such a manner as to provide a rain-proof seal. The insulating panels, covered with a previously-applied layer of covering panels 30 made, for example, of asbestos cement, are then applied. Use of the joint according to the invention results in a continuous insulating layer, from which it is impossible to remove individual panels. In this case too, the insulating panels 1 have criss-crossed grooves 20 on their upper and lower surfaces. Rain that falls on the upper surface can, as is shown at 31, flow through the open seams of the covering plate 30 into the upper grooves, passing from there through the hooked step joint 11, that is not completely closed, thus reaching the underside of the insulating panel 1, from where it runs off in the area of the lower grooves 20 over the roof sealer 29 to the cavetrapping, that is not shown in the drawing.

A B S T R A C T

A shape-locking joint connector for panel-formed construction elements that uses no separate connecting parts, is disclosed. The connector is characterized in that on one edge of the construction element there is a rounded channel that is open to the outer surface of the construction element, said channel being followed by an edge strip. On the side opposite the edge strip, the channel has a stop strip which is flush with the outer surface and protrudes into the space formed by said channel, while the corresponding edge of the adjacent construction element is of a shape that corresponds to this configuration to ensure form-locking engagement with the edge.